



**IPIA
104TH
CONVENTION
EXHIBITOR
&
SPONSOR
PROSPECTUS**

November 11-14, 2021

**THE DIPLOMAT
BEACH RESORT & SPA
HOLLYWOOD, FLORIDA**



SUPPLIER MEMBER/EXHIBITOR INFORMATION

DEAR IPIA SUPPLIER MEMBER/EXHIBITOR,

We are excited that you are considering joining us in Hollywood, Florida at the Diplomat Beach Resort for our 104th Annual Convention & Trade Show.

This packet will give you the key information that you need in order to be an Exhibitor at the convention.

1. KEY DATES – Listed below are some key dates to mark on your calendar:

- **FRIDAY, MAY 14, 2021** – We will host a Zoom conference call for Exhibitors on Friday, May 14 at 1:00 pm ET/12:00 pm CT/11:00 am MT/10:00 am PT to address any questions you may have before registration opens. We will review our new Exhibitor online registration process as well as discuss specifics about the hotel, load in, exhibit hall, and layout.

Please keep in mind that this call is optional- you are not required to participate. A Zoom link will be emailed out for the call at least a few days prior.

- **TUESDAY, MAY 18, 2021** – Booth registration for the IPIA Convention will open at 12:00 pm ET/11:00 am CT/10:00 am MT/9:00 am PT. Forms will be accepted on a first come first serve basis through an online registration link. All forms will need to be submitted through this online registration link **after** 12:00 pm EST. Any forms submitted before 12:00 pm EST will need to be re-submitted (after 12:00 pm) which could delay the process.

- **FRIDAY, JUNE 18, 2021** – All booth & sponsor invoices will be emailed out by this date.

- **MONDAY, JULY 5, 2021** – IPIA Convention registration opens at www.packagedice.com. You will receive an email with the registration link when it is live. It is important to remember that your booth registration is SEPARATE than the attendee registration (and is a separate fee).

- **WEDNESDAY, AUGUST 18, 2021** – All invoices for Exhibit booths and Sponsorships need to be paid in full by August 18, 2021. Any companies that do not pay their invoice on a timely basis runs the risk of late fees or re-assignment in the Exhibit Hall.

2. REGISTRATION – Please remember that the IPIA Booth registration is separate than the attendee convention registration.

BOOTH PRICES – First Booth \$695.00 Additional Booths \$425 each

Please complete the IPIA Booth and Sponsorship registration on Tuesday, May 18 to secure your booth location/sponsorship and the IPIA attendee online registration after July 5th to secure your convention registration.

3. SPONSORSHIP – Sponsorship opportunities create a unique way to highlight your company and set it apart from your competitors. We recommend setting yourself apart by participating in what is a proven marketing tool. The IPIA greatly appreciates the support of our sponsors.

Please review the sponsorship options and indicate if you would like to be a sponsor on your Booth Registration form. Please contact Karen at Suncoast Meetings for any questions on Exhibits or Sponsorships at karen@suncoastmeetings.com or (813) 852-1977.

SUPPLIER MEMBER/EXHIBITOR INFORMATION

4. **BILLING OF CONVENTION BOOTH & SPONSORSHIP CHARGES** – We will invoice all companies by **Friday, June 18, 2021**. You have the option to pay by credit card or check for the Booth registration and sponsorships. Invoices will have a due date of **Wednesday, August 18, 2021**. Any invoices received after this date will need to be paid by credit card. **IMPORTANT – Please note that there is a 3% processing fee added to your invoice for those choosing to pay by credit card.**
5. **AGENDA/SCHEDULE** – A preliminary Convention agenda is included in this Exhibitor prospectus. Please remember that this is subject to change.
 - **EXHIBITOR SETUP** – Wednesday, November 10th from 12:00 pm-9:00 pm and Thursday, November 11th from 7:30 am-4:30 pm.
 - **EXHIBITOR BREAKDOWN** – Saturday, November 13th from 10:00 am-4:00 pm.
6. **CONVENTION PATTERN** – The main days of the convention will be:
 - **THURSDAY, NOVEMBER 11** – Opening Session, Keynote Speaker and Exhibit Hall Grand Opening
 - **FRIDAY, NOVEMBER 12** – Breakfast in Exhibit Hall, Annual Business Meeting, Plant Tour, Cocktail Reception in Exhibit Hall
 - **SATURDAY, NOVEMBER 13** – Breakfast in Exhibit Hall closes at 10:00 am, Exhibit Hall Breakdown, Sessions, Chairman’s Party
7. **EXHIBITOR PRIZE CONTRIBUTION** – All Supplier companies are asked to contribute \$125 for Exhibit Hall door prizes throughout the convention. This helps us keep Industry members in the hall and interacting with our Exhibitors.
8. **SLEEPING ROOM RESERVATIONS** – There will be a link on the IPIA website for sleeping room reservations by Monday, May 24, 2021. We encourage you to book early as we anticipate this to be a popular convention location.
9. **EXHIBIT HALL POLICIES & PROCEDURES** – We have some Exhibitor policies & procedures in the next section of the Exhibitor Prospectus. Please take the time to educate yourself on these policies as you prepare for the IPIA Convention & Trade Show.
10. **CANCELLATION** – There are no refunds on booth registrations after September 10, 2021. There are no refunds on sponsor registrations after June 1, 2021.

WE ARE HERE TO HELP – *Please reach out if we can assist with any questions or make your IPIA Exhibitor experience better!*

Maria Maggio
Executive Director
IPIA

Karen Farrington, CMP
IPIA Meeting & Event Manager
Suncoast Meetings & Events

Ben Albrechts
IPIA Assoc. Conf. Chair
Leer Inc.



IPIA EXHIBITOR POLICIES and PROCEDURES

IPIA MEMBERSHIP

Companies must be an IPIA Associate Member to exhibit at the Convention & Trade Show. All member suppliers must have a booth and at least (1) full registration at the Convention to attend the Convention.

ATTENDANCE AND EXHIBIT HALL

Attendance at the Convention by a supplier to the industry will be only on a registered supplier basis, not as a guest pass, ice company registration, or other non-supplier basis. Registered supplier companies must be members of the IPIA and participate in trade show activities by purchasing a booth or table-top display as outlined in the Supplier Prospectus. Only bona fide employees of registered companies are allowed in the registered companies' booths. Exceptions must be approved by the Associate Member Conference Chair and Executive Director. Possible exceptions are:

- Subcontractors providing technical expertise and who will be selling through the registered supplier, and
- A registered supplier's representative that does not sell directly to the industry other than through that registered supplier.

During exhibit hours, selling and soliciting of attendees will be limited to the booth or the common areas, not aisles or in other Exhibitors' booths. Booth must be staffed the entire time of the official exhibit hall hours. Exhibitors are prohibited from assigning or subletting a booth or any part of a space allotted to them. Selling at a Convention in any form will be performed only by registered participants. Only registered participants will be allowed to be in the Exhibit Hall. The booth shall contain and advertise only products or services manufactured, sold, or distributed by the Exhibitor.

ENTERTAINMENT

Exhibitors are prohibited from sponsoring or scheduling private events such as cocktail parties, tours, seminars, etc. during Convention functions. This does not preclude sponsorship of official IPIA-sponsored events as outlined in the Convention prospectus. IPIA sponsorships must be paid in full prior to the Convention, according to the payment terms listed in the Supplier Prospectus.

PHOTOGRAPHS AND VIDEOS

An Exhibitor may not photograph or videotape the exhibits or products of other Exhibitors without their permission. Attendees or Exhibitors violating this policy will be asked to leave the Exhibit Hall and will not be readmitted.

ADMISSION TO THE EXHIBIT HALL

Admission to the Exhibit Hall will be with a badge which is received after registration and payment of fees. Attendees agree to comply with the Exhibit Hall rules. Adequate precautions by the Convention security team will be taken to ensure that only authorized persons are admitted to the exhibit area.

- **Exhibit Hall setup** - The Exhibit Hall will be limited to Exhibitors only during setup hours. There will be an individual from the meeting management/security team

monitoring the entrance to strictly enforce admission as well as making periodic sweeps through the Hall.

- **Daytime Hours** - During the daytime exhibit hall "official" hours (as listed in the Convention agenda), anyone can be in the Hall that has an appropriate badge. (This does limit spouse passes in the morning, as their pass does not include breakfast.)
- **After Hours** - The Exhibit Hall will be locked down during the overnight hours by hotel security 30 minutes after the official closing of the Hall at night. Please keep in mind that IPIA and the hotel are not responsible for anything left in the Hall, although we will make every effort to ensure the Hall is appropriately locked down.

All attendees will need to leave the Hall within 30 minutes of the posted close time of the hall. A member of the security team will be present when the Hall is closed during daytime hours.

CONDUCT OF EXHIBITORS

Exhibitors shall conduct themselves in an ethical manner and in conformance with these policies and procedures. Meeting Management reserves the right to deny the privileges to the Hall to any Exhibitor(s) who do not comply with the policies and procedures. Exhibitor's badges are personal, not transferable, and must be worn at all times.

INSURANCE AND LIABILITY

The Exhibitor assumes all responsibility for any and all loss, theft, or damage to Exhibitor displays, equipment, and/or property while on site at the host property and waives any claim or demand that it may have against the IPIA, the host property, or Meeting Management arising from such loss, theft, damage or injuries to its agents, employees, or other persons, no matter if sustained from fire, theft, accident, or other causes. All claims for such hereby are expressly waived by the Exhibitor.

CARE OF PREMISES

Exhibitor shall not injure, mar, or in any manner deface the floors, walls, fixtures, or any part of the building. If the Exhibitor, its agents, or guests shall cause anything to be done whereby the premises shall in any manner be injured, marred, or defaced, the Exhibitor shall pay to the Building Management such sum as may be necessary to restore the premises to their previous condition.

EXHIBIT GUIDELINES

All Exhibitors must adhere to booth display guidelines provided by IPIA in the Supplier Prospectus. All dimensions and locations shown on the official floor plan are believed, but not warranted to be accurate. IPIA reserves the right to make such modifications to the official floor plan as may be necessary to meet the needs of Exhibitors.

UNDERSTANDING OF IPIA EXHIBITOR POLICIES & PROCEDURES

Please be aware that by completing the Exhibitor Booth Registration Form, you are confirming that you have reviewed these policies and procedures and agree to follow them as an IPIA Exhibitor at the Annual Convention & Trade Show.

AGENDA *(Subject to change)*

WEDNESDAY, NOVEMBER 10, 2021 (Early Arrival Day)	
9:00 am – 12:30 pm	Executive Committee Meeting
12:00 pm – 9:00 pm	Supplier Optional Exhibit Setup <i>(Restricted to Suppliers Only)</i>
2:00 pm – 5:00 pm	Board of Directors/Committee Meeting
6:30 pm	Board of Directors/Committee Dinner <i>(offsite)</i> or Dinner on own
THURSDAY, NOVEMBER 11, 2021	
7:00 am – 1:30 pm	16 th Annual Mel Eads Memorial Golf Tournament <i>(Meet in lobby for bus 7:00am (8:00am shotgun)</i>
7:30 am – 4:30 pm	Supplier Exhibit Setup <i>(Restricted to Suppliers Only)</i>
3:00 pm – 4:00 pm	Welcome Opening Session, Awards & Gold Sponsor Presentations
4:00 pm – 5:00 pm	Keynote Speaker
5:15 pm – 5:45 pm	First Timers/Applicants Reception
6:00 pm – 8:30 pm	Exhibit Hall Grand Opening & Reception
FRIDAY, NOVEMBER 12, 2021	
7:00 am – 7:45 am	Roger Breisch Memorial Fun Run/Walk
8:00 am – 9:15 am	Canadian Association of Ice Industries (CAII) Breakfast Meeting
8:00 am – 9:15 am	Breakfast in the Exhibit Hall
8:00 am – 11:00 am	Exhibit Hall Open
9:00 am	Ladies/Spouse Event <i>(Must be registered to attend)</i>
11:15 am – 12:45 pm	Annual Business Meeting & Awards
12:45 pm	Buses Depart for Ice Plant Tour
1:00 pm – 5:00 pm	Ice Plant Tour & Lunch
5:30 pm – 7:30 pm	Exhibit Hall Open – Light Cocktail Reception
7:30 pm	Open Night
SATURDAY, NOVEMBER 13, 2021	
7:00 am – 7:45 am	Roger Breisch Memorial Fun Run/Walk
8:00 am – 9:15 am	Past Chairman Breakfast
8:00 am – 9:15 am	Breakfast in the Exhibit Hall
8:00 am – 10:00 am	Exhibit Hall Open
10:00 am – 4:00 pm	Exhibit Hall Teardown
10:15 am – 11:30 am	Focus Session
11:30 am – 12:45 pm	Roundtable Session
1:00 pm – 4:00 pm	Optional Tour OR Open Afternoon
7:00 pm – 10:00 pm	Chairman’s Party
SUNDAY, NOVEMBER 14, 2021 – SAFE TRAVELS HOME!	

BOOTH AND EXHIBIT HALL INFORMATION

BOOTHS

- All Booths are 8' x 10'.
- Aisle size varies – see diagram.
- Booth cost includes 8' high back drape and 3' high side drape and Company sign.
- All other furniture and electrical needs (tables, chairs, plants, wastebasket, etc.) must be ordered through Eddy Exhibition Services/Goben Inc. when service kits are sent out.
- Exhibitor service kits will be emailed out by July 15, 2021.
- The Exhibit Hall is in a ballroom that is already carpeted. You do not need to order carpet unless you would like carpet customized for your booth.
- **Booth Limit** – 6 booths per exhibiting company and minimum of (1) booth per supplier company.

SPECIAL NOTES

Booth requests will be done on a first come/first serve basis beginning on Tuesday, May 18, 2021 at 12:00 pm ET/11:00 am CT/10:00 am MT/9:00 am PT.

We will make every effort to accommodate your requests – please note: Gold, Silver & Bronze Sponsors receive first consideration with booth location requests. We also consider the sponsorship level that companies have participated in at the IPIA Convention & Trade Show over the past (5) years.

HOTEL/EXHIBIT HALL INFORMATION

The Exhibit Hall is located in the Grand Ballroom at the Diplomat Beach Resort and the ceiling height is 23' high throughout the Ballroom. **IMPORTANT** - There is a freight elevator at this hotel allowing street and dock high access. The maximum weight is 20,000 lbs.

Defining measurement for access to Grand Ballroom (via loading dock and freight elevator) is 8'5" x 8'5".

Please contact the Suncoast Meetings office if your equipment cannot fit in the ballroom based on these measurements so we can discuss and review any options. If you need information on compressed air access or drainage, please contact Karen at Karen@suncoastmeetings.com for more details.

SUNCOAST MEETINGS & EVENTS, INC. is our Meeting management company and will be handling all Exhibit Requests and Assignments with IPIA Executive Director.

Karen Farrington, CMP
Phone: (813) 852-1977
kipia@suncoastmeetings.com

**EDDY EXHIBITION SERVICES, INC/
GOBEN CONVENTION SERVICES**
Official Show Decorator
Phone: (407) 872-2223
orders@gobencs.com

For specific questions on the Exhibit Hall/Facility please contact Joe Eddy at jeddy@eddyexhibitionservices.com.



THE DIPLOMAT BEACH RESORT – GRAND BALLROOM

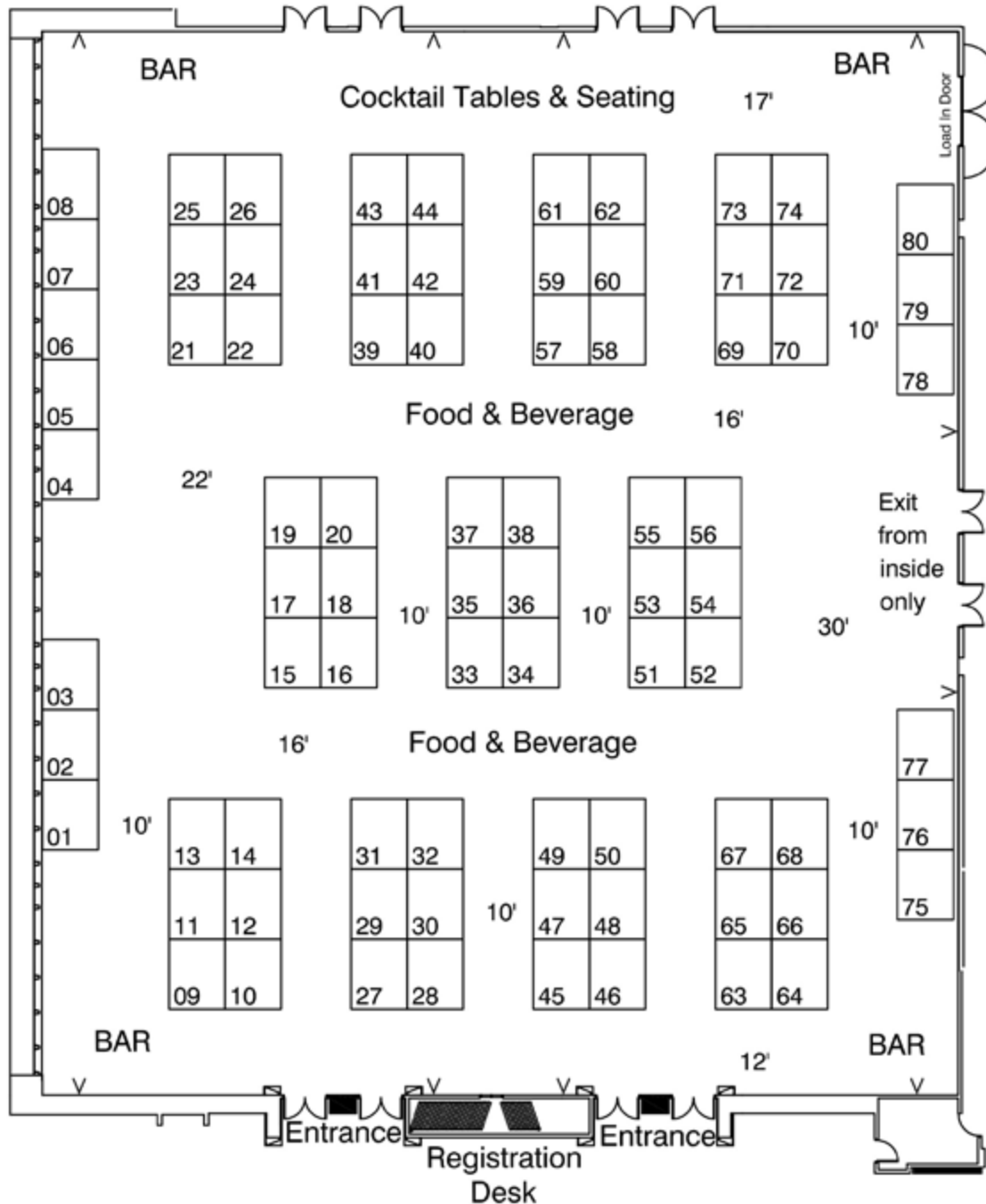

EXHIBITOR/SPONSOR ONLINE REGISTRATION INSTRUCTIONS

- **Online Booth/Sponsor registration** - We are moving to an online registration process that will allow you to complete your booth registration, request booth location and request sponsorships. The link will be available on Friday, May 14th before we open up Exhibitor/Supplier registration on Tuesday, May 18th.
- **Questions** – We will be sending our detailed instructions and reviewing this new process on Friday, May 14th during the Exhibitor/Supplier overview Zoom call.

SPONSORSHIP OPPORTUNITIES

EVENT SPONSORED	DAYS/DATE	CONTRIBUTION
GOLD SPONSORSHIP		
Keynote Speaker	Thursday 11/11	\$3,500
Opening Reception, Exhibit Hall	Thursday 11/11	\$3,500
Light Cocktail Reception with Signature Cocktail Contest	Friday 11/12	\$3,500
Chairman's Party <i>(2) Gold sponsorships available for this event</i>	Saturday 11/13	\$3,500
SILVER SPONSORSHIP		
Opening Session Refreshments & Snacks	Thursday 11/11	\$2,200
Breakfast in Exhibit Hall	Friday 11/12	\$2,200
Ice Plant Tour Transportation	Friday 11/12	\$2,200
Ice Plant Tour Lunch – Reddy Ice	Friday 11/12	\$2,200
Breakfast in Exhibit Hall	Saturday 11/13	\$2,200
Entertainment, Chairman's party	Saturday 11/13	\$2,200
BRONZE SPONSORSHIP		
Fun Run/Walk	2 days	\$1,200
Cell phone charging station in Exhibit Hall	3 days	\$1,200
Golf Tournament Beverage Cart	Thursday 11/11	\$1,200
Ice Sculpture with Convention logo	Thursday 11/11	\$1,200
Entertainment in Exhibit Hall (2nd night)	Friday 11/12	\$1,200
Coffee Break (AM)	Friday 11/12	\$1,200
Coffee Break (AM)	Saturday 11/13	\$1,200

The following items are available for company personalization at item cost and are available only to event sponsors:

- Name Badge Holders for Industry Members
- Attendee Bags
- Registration Packets
- Pads/Pens in General Session
- Golf Towel/Balls
- Personalized Room Key Cards



SPONSORSHIP BENEFITS

GOLD SPONSORSHIP ■ \$3,500 includes

Gold Sponsors will have the opportunity to do a 3-5 minute introduction (AV presentation is optional) in the Opening Session.

Featured as Gold Sponsor in each IPIA E-news starting in August.

Listing on convention Mobile App as Gold Sponsor with link to website.

Use of branded Gold Sponsor logo in email and print materials.

Meet and Greet – Sponsor Team members can meet and greet attendees at their sponsored event and are given opportunity to provide a welcome.

Priority Booth choice

Gold Sponsor Ribbon on Name Badge

Sponsor List Displayed at the Registration Counter

(2) Sponsor Signs with logo at the Sponsored Event

Gold Sponsor recognition in booth

SILVER SPONSORSHIP ■ \$2,200 includes

Priority Booth choice (after Gold Sponsors)

Special Recognition at the General Session

Listing on convention Mobile App as Silver Sponsor with link to website

Use of branded Silver Sponsor logo in email and print materials.

Sign at the Sponsored Event with logo

Silver Sponsor Ribbon on Name Badge

Sponsor List Displayed at the Registration Counter

Silver Sponsor recognition in booth

BRONZE SPONSORSHIP ■ \$1,200 includes

Priority Booth choice (after Gold and Silver sponsors)

Special Recognition at the General Session

Listing on convention Mobile App as Bronze Sponsor with link to website

Use of branded Bronze Sponsor logo in email and print materials.

Sign at the Sponsored Event with logo

Bronze Sponsor Ribbon on Name Badge

Sponsor List Displayed at the Registration Counter

Bronze Sponsor recognition in booth

BOOTH GUIDELINES

These guidelines for IPIA Display regulations have been created to promote continuity and consistency in the exhibit hall and are based on generally recognized North American Guidelines for Displays. The IPIA Tradeshow is fairly small in size as compared to most trade shows, thus we have kept the regulations as simple as possible.

Due to the nature of our large equipment exhibits, exceptions can be made with approval from the IPIA and exhibiting facility. If you have any questions regarding booth design please contact Suncoast Meetings & Events, Inc. at ipia@suncoastmeetings.com.

- **DISPLAY VISION** – All exhibitors are equal regardless of size and should be given an equal opportunity, within reason, to present their product in the most effective manner to the audience.
- **EXHIBITOR'S RESPONSIBILITY** – “Be a good neighbor” IPIA Exhibit booths are 8' x 10' in size, unless multiple booths are purchased.
- **LINEAR BOOTH** – Has only one side exposed to an aisle and is generally arranged in a series along a straight line.
- **PERIMETER BOOTH** – Is a linear booth that backs up to a wall of the exhibit facility rather than to another exhibit.
- **ENDCAP BOOTH** – Is a booth exposed to aisles on three sides and composed of a minimum of two booths which backs up to linear booths.
- **SPLIT ISLAND BOOTH** – Is a peninsula booth that backs up to another peninsula booth.
- **ISLAND BOOTH** – Is a booth(s) exposed to aisles on all four sides.

ARRANGING DISPLAY MATERIAL REGULATIONS

- **Display Materials** – Should be arranged in such a manner so as not to obstruct sight lines of neighboring exhibitors.
- **Split-Island Booths and Island Booths** – May use the entire cubic content of the booth up to a maximum height of 18'.
- **Perimeter Booths** – All linear booth rules defined below apply except the back wall height restriction is 14' including signage.
- **Endcap Booths** – The backwall is restricted to 4' high within 4' of the aisle. 8' height restriction for the remainder (or center section not within 4' of the aisle).
- **Linear Booths** – The rear half of the booth(s) is restricted to a maximum height allowance of eight feet (8') with a four foot (4') height limitation in the remaining space forward to the aisle. If more than one linear booth is used as a single exhibit space, the 4' height limitation is applied only to that portion of exhibit space which is within 10' of an adjoining booth.

OTHER BOOTH ISSUES

- All exhibit displays should be designed and erected in a manner that will withstand normal contact, vibration and moderate wind effects.
- All materials used in display construction or decorating should be made of fire retardant materials.
- No lighting is allowed or should be projected outside the boundaries of the exhibit space. Specialized lighting (i.e., spins, rotates) should be in good taste and not interfere with neighboring exhibits. Potentially harmful lighting such as lasers is prohibited.

Some of the attached layouts reflect a 10' x 10' booth. Adjust depth dimensions accordingly for 8' x 10' booth as shown in the Linear Booth drawing.

BOOTH LAYOUTS

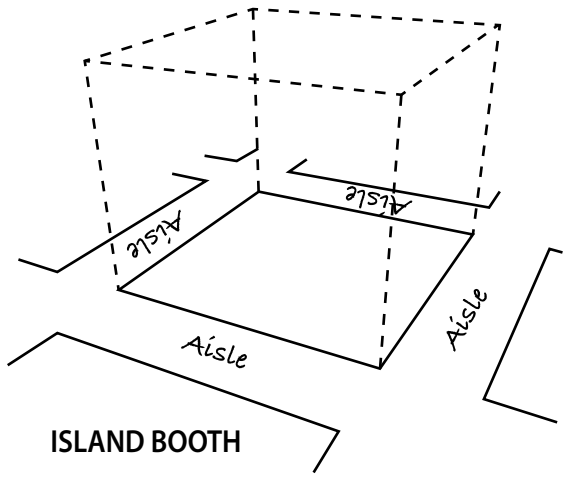

ISLAND BOOTH

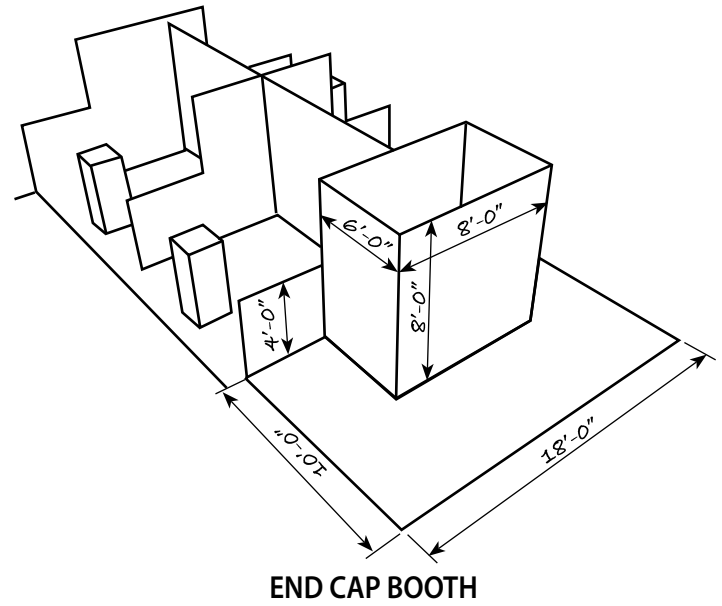

END CAP BOOTH

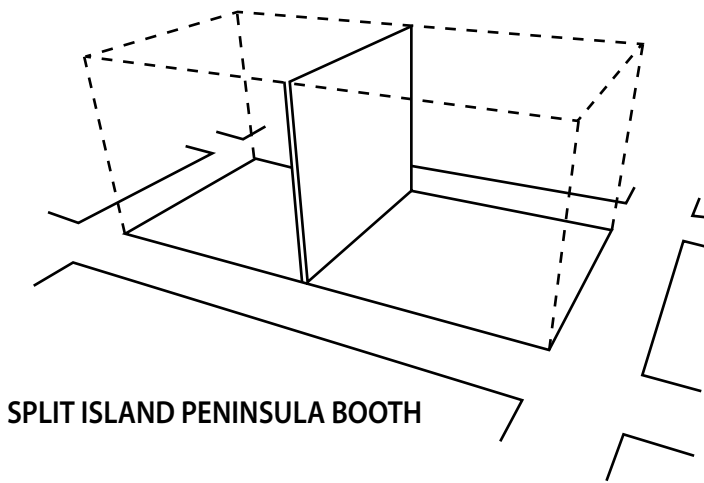

SPLIT ISLAND PENINSULA BOOTH

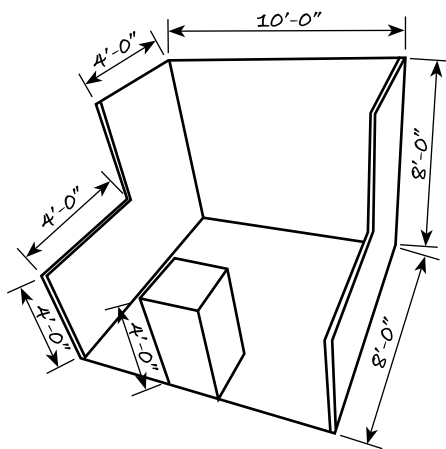

8' x 10' LINEAR BOOTH

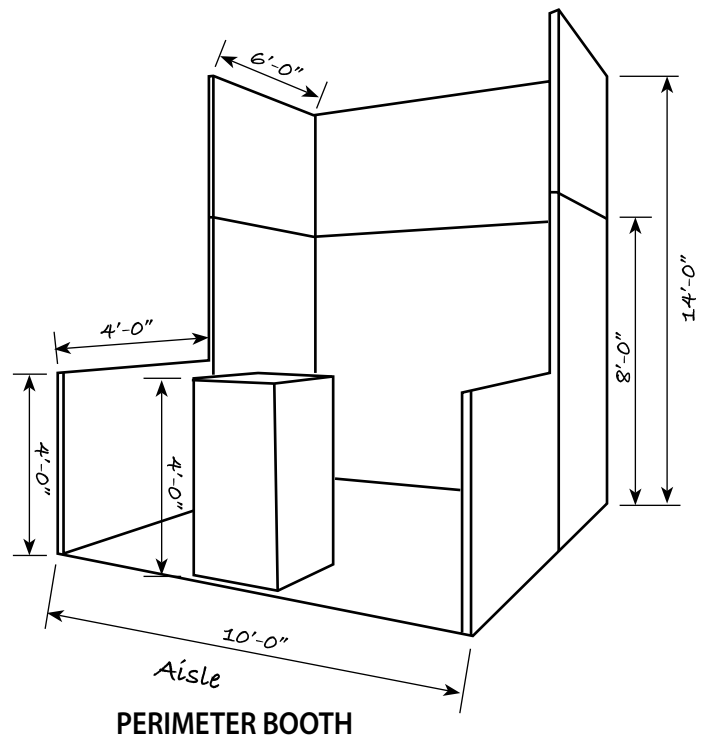

PERIMETER BOOTH